

**Please note**

For this application we would recommend an exhaust constant volume device is fitted to the cabinet duct.

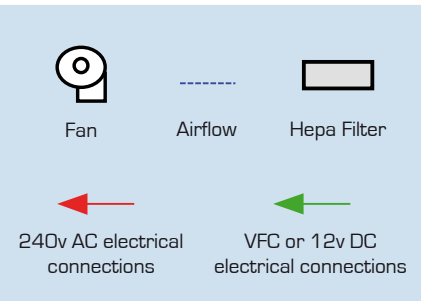

**Generation 6 standard features**

1. Fixed open front with nightdoor
2. One piece working tray
3. Gas strut aided lift up door for cleaning
4. Perforated mesh to prevent tissues from sucked up into the fans
5. Stainless steel interior panels
6. Cabinet body painted white including interior panels
7. Work area electrical socket or sockets.

**Optional extras**

1. Support stand (optionally flat pack)
2. UV lamp
3. Gas Solenoid
4. Tray unit to fit to support stand
5. Fumigation adaptor kits
6. Hydrogen peroxide ports
7. Carbon filter fumigation unit
8. Fumigation boiler

**Title** Class 2 with common discharge duct

**Date** October 2008

**Sheet** 1-1

**Revision** 1.0